

MARK	REVISION DESCRIPTION	DATE	DRAWN	APPROVED
△				
△				
△				

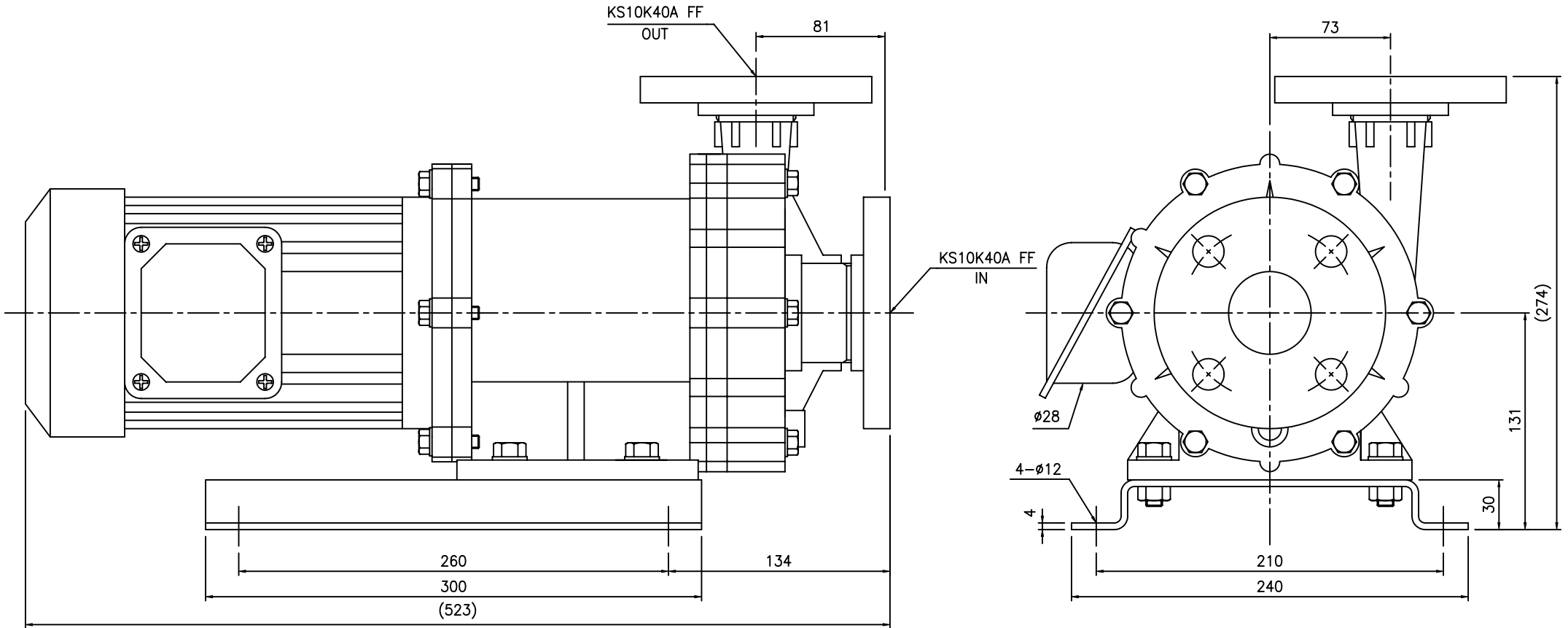

PUMP SPECIFICATIONS		
FREQUENCY (Hz)	50	60
MAX.HEAD (M)	12.5	17.5
MAX.CAPACITY (L/min)	270	300
STAND.CAPACITY (L/min)	160 AT 7.5M	170 AT 11M
MAX.SP.GR.	1.8	
ROTATION (MOTOR FAN)	CLOCKWISE	
MOTOR OUTPUT (kW)	3 ϕ 1.5	
APPROX.WEIGHT (kg)	27	

ITEM NO	NO.	DESCRIPTION	SIZE	MAT'L	Q'TY	REMARK
		FILE NAME	MS00F-06	도명TITLE	OUTLINE DRAWING	
		APPROVED		MX-300 MAGNETIC DRIVE PUMP		
		CHECKED		도번 DWG NO 840006		
		DESIGNED				
관련도면	적용품목	DRAWN				
STORAGE NO.		작성부서	DATE			
ORG.DWG		연구개발부	2004.09.21			