

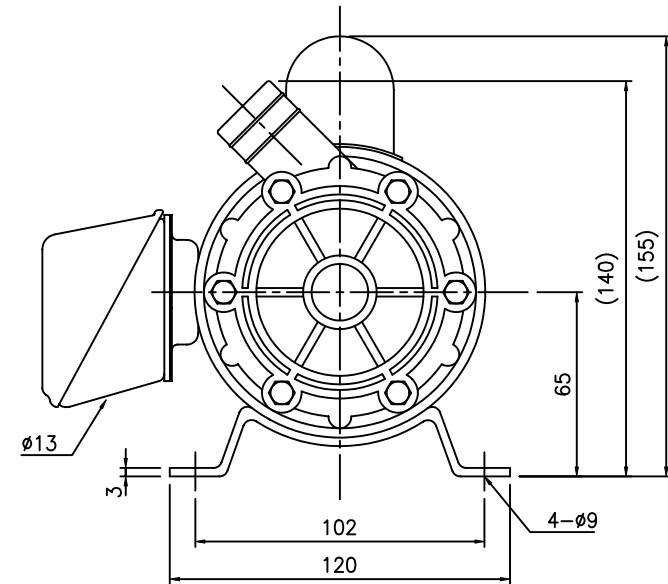

MARK	REVISION DESCRIPTION	DATE	DRAWN	APPROVED
△				
△				
△				
△				

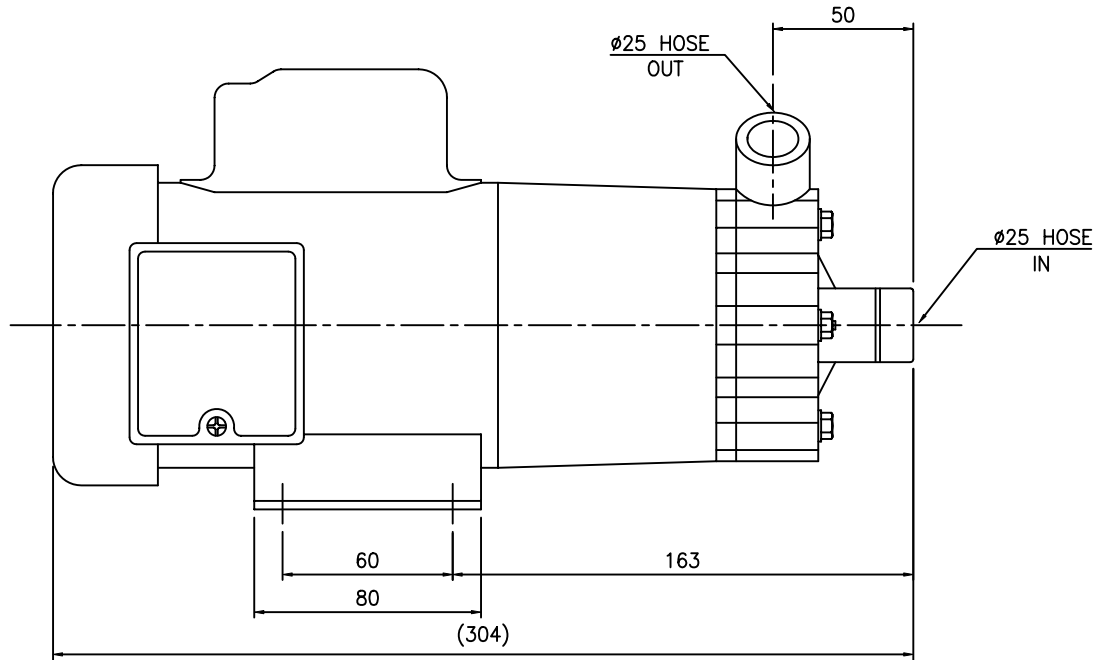

PUMP SPECIFICATIONS		
FREQUENCY (Hz)	50	60
MAX.HEAD (M)	3.2	4.5
MAX.CAPACITY (L/min)	75	85
STAND.CAPACITY (L/min)	45 AT 2M	65 AT 2M
MAX.SP.GR.	1.1	
MOTOR OUTPUT (W)	1ø 65	
APPROX.WEIGHT (kg)	5.6	

ITEM NO	NO.	DESCRIPTION	SIZE	MAT'L	Q'TY	REMARK	
	소재	MAT'L	소재	수	MAT'L DIM	중량 WEIGHT	척도 SCALE N/S(0.5)
	FILE NAME	MS00H-03	도명	TITLE	OUTLINE DRAWING		
	APPROVED		MX-85 MAGNETIC DRIVE PUMP				
	CHECKED		도번	DWG NO	840003		
	DESIGNED						
관련도면	적용품목	DRAWN					
STORAGE NO.	작성부서	DATE	 천세산업 주식회사 CHEON SEI IND. CO.,LTD.				
ORG.DWG	연구개발부	2004.09.21					